

FM TUNER SOLUTIONS

PRODUCT BRIEF

SigmaTel, as the worldwide market leader for portable digital audio technologies, enables companies to bring to market unique flash and hard drive based MP3 players through patented semiconductor and software solutions. SigmaTel's integration and support allows customers to develop devices with the longest battery life, smallest form factors, fastest time-to-market, and lowest system design costs in the market.

Developed with an optimized radio architecture, the STFM1000 is a highly integrated, low power, single chip FM tuner designed to provide FM radio capabilities when combined with SigmaTel's fourth generation STMP3600 and industry-leading STMP3500 series audio SoCs. These powerful combinations can be used to power digital audio players, PDAs, voice recorders, cell phone, portable video players, and digital photo wallets.

The optimized radio architecture is designed to offer low power consumption, minimal external components for small form factor, and low cost through an optimum system partitioning and features integrated automatic channel selectivity, demodulation, and stereo decoding. In addition, a complete software development environment will be available as part of SigmaTel's world class software development kit for portable media players.

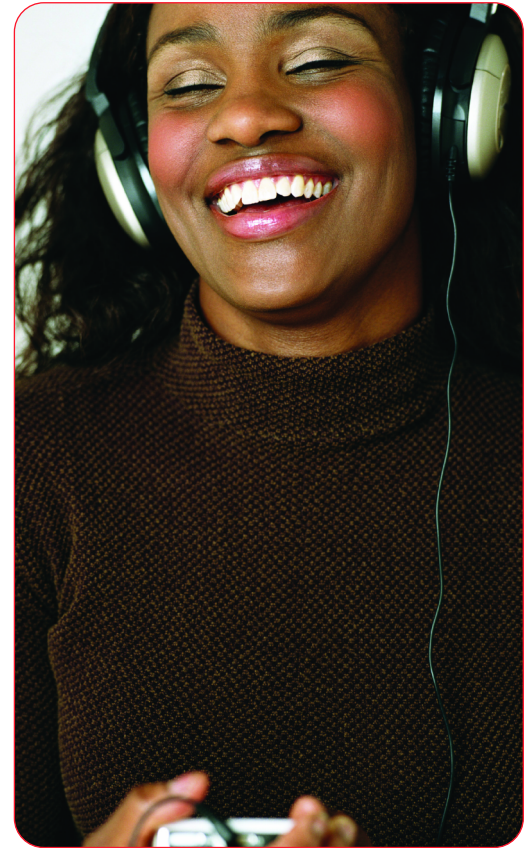

FEATURES

- **FM COMPANION CHIP TO SIGMATEL'S STMP3600 AND STMP3500 PORTABLE MEDIA SOC**
 - Allows for optimum system partitioning, flexibility, and reduced cost
 - No need for separate module solution
 - Uses 24 MHz crystal to generate clock for Host SOC to save cost and board space
- **U.S./EUROPE/JAPAN BAND CAPABILITY IN 100 KHZ STEPS**
- **HIGH SENSITIVITY DUE TO INTEGRATED LOW-NOISE RF AMPLIFIER**
- **RF AUTOMATIC GAIN CONTROL (AGC)**
- **AUTOMATIC INTERNAL CHANNEL SELECTIVITY**
- **PLL-BASED SYNTHESIZER TUNING SYSTEM**
- **RDS-COMPATIBLE (ENABLED VIA SOFTWARE UPGRADE)**
 - STMP3600 only
- **ADJUSTMENT-FREE STEREO DECODER**
- **INTER-IC COMMUNICATION BUS (I2C) SUPPORT UP TO 400 KBPS.**
- **HOST SOC SOFTWARE PROGRAMMABLE:**
 - Stereo Blend, Hi-Cut, and SoftMute
 - Attack/decay times for signal quality indicators
 - Search/Stop function
 - FM record via ADPCM

BENEFITS

- **DELIVERS A COMPLETE SOLUTION FOR ADDING FM RECEPTION TO MP3 PLAYERS AND OTHER APPLICATIONS WHEN COUPLED WITH THE STMP3600 AND STMP3500 SERIES**
- **OPTIMAL SOLUTION PARTITIONING FOR POWER CONSUMPTION, BOARD SPACE, AND COST**
- **DELIVERED AS PART OF COMPREHENSIVE SOFTWARE DEVELOPMENT KIT (SDK) WHICH ALLOWS CUSTOMIZATION FOR QUICK TIME TO MARKET**

STFM1000 SPECIFICATIONS

- **Input Sensitivity – 2 μ V**
22.5 kHz freq deviation, 26 dB SNR, de-emphasis = 75 μ s, faudio=1k, L=R
BW = 300 Hz – 15 kHz

- **Channel Frequency Range with 100 kHz steps – 76 to 108 MHz**

- **Channel Selectivity – 57 dB**
 \pm 200 kHz channel, 22.5 kHz freq deviation, de-emphasis = 75 μ s, faudio=1k, L=R

- **Maximum Signal to Noise Ratio (SNR) – 60 dB**
22.5 kHz freq deviation, de-emphasis = 75 μ s, faudio=1k, L=R
BW = 300 Hz – 15 kHz

- **Total Harmonic Distortion (THD) – 0.1%**
75 kHz freq deviation, de-emphasis = 75 μ s, faudio=1k, L=R
BW = 300 Hz – 15 kHz

- **Stereo Separation – 33dB**
75 kHz freq deviation, de-emphasis = 75 μ s, faudio=1k, L only, 9% pilot
BW = 300 Hz – 15 kHz

- **Power Consumption for STFM1000 – 42mW**

- **Power Supply**
DVDD1, AVDD1, AVDD2, AVDD4 – 1.35 V
DVDDIO, AVDD3 (3.3V I2C I/O and PLL) – 3.0V

STFM1000 BLOCK DIAGRAM

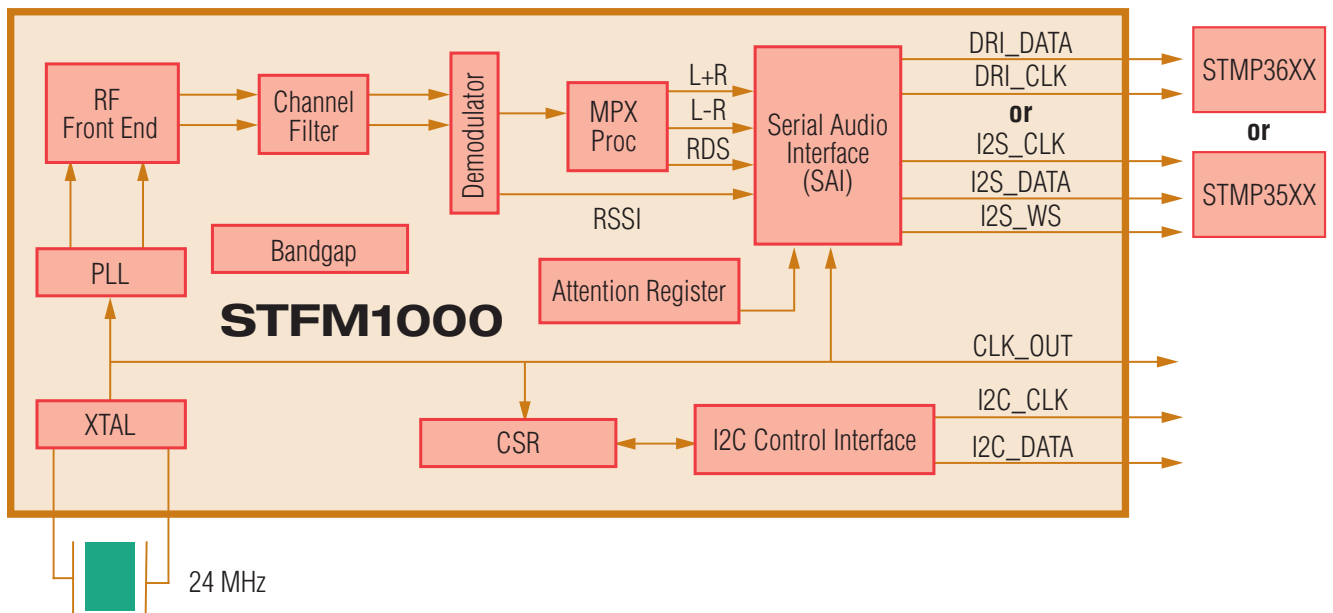

email: sales@sigmatel.com

www.sigmatel.com — tel: (512) 381-3700

Copyright © 2005 SigmaTel, Inc. All rights reserved. SigmaTel is a registered trademarks of SigmaTel. All other companies and products as they appear are trademarks or registered trademarks of their respective holders.